

Magnetoresistance and Hall effect of Bismuth

OBJECTIVES:

- (I) To determine magnetoresistance of Bi
- (II) To determine the Hall coefficient of Bi

INTRODUCTION

Magnetoresistance:

It is noticed that the resistance of a sample changes when the magnetic field is turned on. The **Magnetoresistance** is the property of a material to change the value of its electrical resistance when an external magnetic field is applied to it. The effect was first discovered by William Thomson (more commonly known as Lord Kelvin) in 1856. The magnitude of the effect is quite low only about 1% at room temperature, but goes to about 50% at low temperatures in giant magneto resistive multilayer structures. More recently effects of more than 95% change in resistivity have been discovered in some perovskite systems.

Magnetoresistance, is due to the fact that the drift velocity of all the carriers is not same. With the magnetic field on; the Hall voltage $V = E_y t = |\mathbf{v} \times \mathbf{H}|$ compensates exactly the Lorentz force for carriers with average velocity; slower carriers will be over compensated and faster ones undercompensated, resulting in trajectories that are not along the applied field. This results in an effective decrease of the mean free path and hence an increase in resistivity. Here the above referred symbols are defined as: \mathbf{v} = drift velocity; E = applied electric field; t = thickness of the crystal; H = Magnetic field

The change in resistivity, $\Delta\rho$, is positive for both magnetic field parallel ($\Delta\rho_{||}$) and transverse ($\Delta\rho_{\perp}$) to the current direction with $\rho_{\perp} > \rho_{||}$. There are three distinct cases of ordinary magnetoresistance, depending on the structure of the electron orbitals at the Fermi surface:

1. In metals with closed Fermi surfaces, the electrons are constrained to their orbit in k-space and the effect of the magnetic field is to increase the cyclotron frequency of the electron in its closed orbit.
2. For metals with equal numbers of electrons and holes, the magnetoresistance increases with H up to the highest fields measured and is independent of crystallographic orientation. Bismuth falls in this class.
3. Metals that contain Fermi surfaces with open orbits in some crystallographic directions will exhibit large magnetoresistance for fields applied in those directions, whereas the resistance will saturate in other directions, where the orbits are closed.

Hall effect:

As you are aware, a static magnetic field has no effect on charges unless they are in motion. When the charges flow, a magnetic field directed perpendicular to the direction of flow produces a mutually perpendicular force on the charges. When this happens,

electrons and holes will be separated by opposite forces. They will in turn produce an electric field (\vec{E}_h) which depends on the cross product of the magnetic intensity, \vec{H} , and the current density, \vec{J} .

$$\vec{E}_h = R \vec{J} \times \vec{H}, \quad (1)$$

where R is called the Hall coefficient.

Now, let us consider a bar of a semiconductor. Let \vec{J} be directed along X direction and \vec{H} along Z direction, then \vec{E}_h will be along Y direction.

Then we could write

$$R = \frac{V_h/y}{JH} = \frac{V_h \cdot z}{IH}, \quad (2)$$

where V_h is the Hall voltage appearing between the two surfaces perpendicular to y and $I=J_y z$ (where 'z' is thickness of bar of a semiconductor)

In general, the Hall voltage is not a linear function of magnetic field applied, i.e. the Hall coefficient is not generally a constant, but a function of the applied magnetic field. Consequently, interpretation of the Hall Voltage is not usually a simple matter. However, it is easy to calculate this **(Hall) voltage if it is assumed that all carriers have the same drift velocity. We will do this calculation for metals and degenerate (doped) semiconductors.**

The magnetic force on the carriers is $\vec{F}_m = e(\vec{v} \times \vec{H})$ and is compensated by the Hall field $\vec{F}_h = e\vec{E}_h$ where \vec{v} is the drift velocity of the carrier ($E_h = vH$)

The current density \vec{J} is the charge q multiplied by the number of carriers traversing per unit area in unit time, which is equivalent to the carrier density multiplied by the drift velocity i.e. $\vec{J} = q n \vec{v}$ (where 'n' is carrier density)

By putting these values in equations (1) and (2)

$$R = \frac{E_h}{JH} = \frac{v \cdot H}{q n v H} = \frac{1}{n q} \quad (3)$$

From this equation, it is clear that the sign of Hall coefficient depends upon the sign of q. Also for a fixed magnetic field and input current, the Hall voltage is proportional to 1/n or its resistivity. The conductivity of the material is $\sigma = nq\mu$, where μ is the mobility of the charge carriers. Thus

$$\mu = R\sigma \quad (4)$$

Equation (4) provides an experimental measurement of mobility; R is expressed in $\text{cm}^3 \text{ coulomb}^{-1}$, thus μ is expressed in units, of $\text{cm}^2 \cdot \text{volt}^{-1} \text{ sec}^{-1}$.

Thus we see that the Hall coefficient, in conjunction with resistivity measurements, can provide information on carrier densities, mobilities, impurity concentration and other values. It must be noted, however, that mobilities obtained from Hall Effect measurements $\mu = R\sigma$ do not always agree with directly measured values. The reason being that carriers

are distributed in energy, and those with higher velocities will be deviated to a greater extent for a given field.

Experimental consideration relevant to all measurements on semiconductors/semimetals

1. In the specimen (bismuth strip) the resistivity may vary smoothly from point to point. In fact, this is generally the case. The question is the amount of this variation rather than its presence. Often however, it's conventionally stated that it is a constant within some percentage and when the variation does in fact fall within this tolerance, it is ignored.
2. High resistance or rectification action appears fairly often in electrical contacts to the specimen and in fact is one of the major problem.
3. Soldered probe contacts, though very much desirable may disturb the current flow (shorting out part of the sample). Soldering directly to the body of the sample can affect the sample properties due to heat and by contamination unless care is taken. These problems can be avoided by using pressure contacts as in the present set-up. The principal drawback of this type of contacts is that they may be noisy. This problem can, however, be managed by keeping the contacts clean and firm.
4. The current through the specimen should not be large enough to cause heating. A further precaution is necessary to prevent 'injecting effect' from affecting the measurement. Even good contacts may have this effect. This can be minimized by keeping the voltage drop at the contacts low. If the surface near the contacts is rough and the electric flow in the crystal is low, these injected carriers will recombine before reaching the measuring probes.
5. For Hall effect experiment, since Hall coefficient is independent of current, it is possible to determine whether or not any of these effects are interfering by measuring the Hall coefficient at different values of current.

Experimental consideration with the measurements of Hall Coefficient.

1. The voltage appearing between the Hall probes is not generally, the Hall voltage alone. There are other galvanomagnetic and thermomagnetic effects (Nernst effect, Righi-Leduc Effect effect and Ettingshausen effect) which can produce voltages between the Hall probes. In addition, IR drop due to probe misalignment (zero magnetic field potential) and thermoelectric voltage due to transverse thermal gradient may be present. All these except, the Ettingshausen effect are eliminated by the method of averaging four readings.

The Ettingshausen effect is negligible in materials in which a high thermal conductivity is primarily due to lattice conductivity or in which the thermoelectric power is small.

When the voltage between the Hall probes is measured for both directions of current, only the Hall voltage and IR drop reverse. Therefore, the average of

these readings eliminates the influence of the other effects. Further, when Hall voltage is measured for both the directions of the magnetic field, the IR drop does not reverse and may therefore be eliminated.

2. The Hall probe must be rotated in the field until the position of maximum voltage is reached. This is the position when direction of current in the probe and magnetic field would be perpendicular to each other.
3. The resistance of the sample changes when the magnetic field is turned on due to magnetoresistance. This is due to the fact that the drift velocity of all carriers is not the same, with magnetic field on, the Hall voltage compensates exactly the Lorentz force for carriers with average velocity. Slower carriers will be over compensated and faster ones under compensated, resulting in trajectories that are not along the applied external field. This results in effective decrease of the mean free path and hence an increase in resistivity.

Therefore, while taking readings with a varying magnetic field at a particular current value, it is necessary that current value should be adjusted, every time. The problem can be eliminated by using a constant current power supply, which would keep the current constant irrespective of the resistance of the sample.

APPARATUS

1. Magnetoresistance and Hall probes
2. Samples: Bismuth for magnetoresistance, Bismuth for Hall effect
3. Constant Current Source, CCS-01
4. Digital Microvoltmeter, DMV-001
5. Electromagnet, Model EMU-75
6. Constant Current Power Supply, DPS-175
7. Digital Gaussmeter, DGM-102
8. Multipurpose stands-2 number

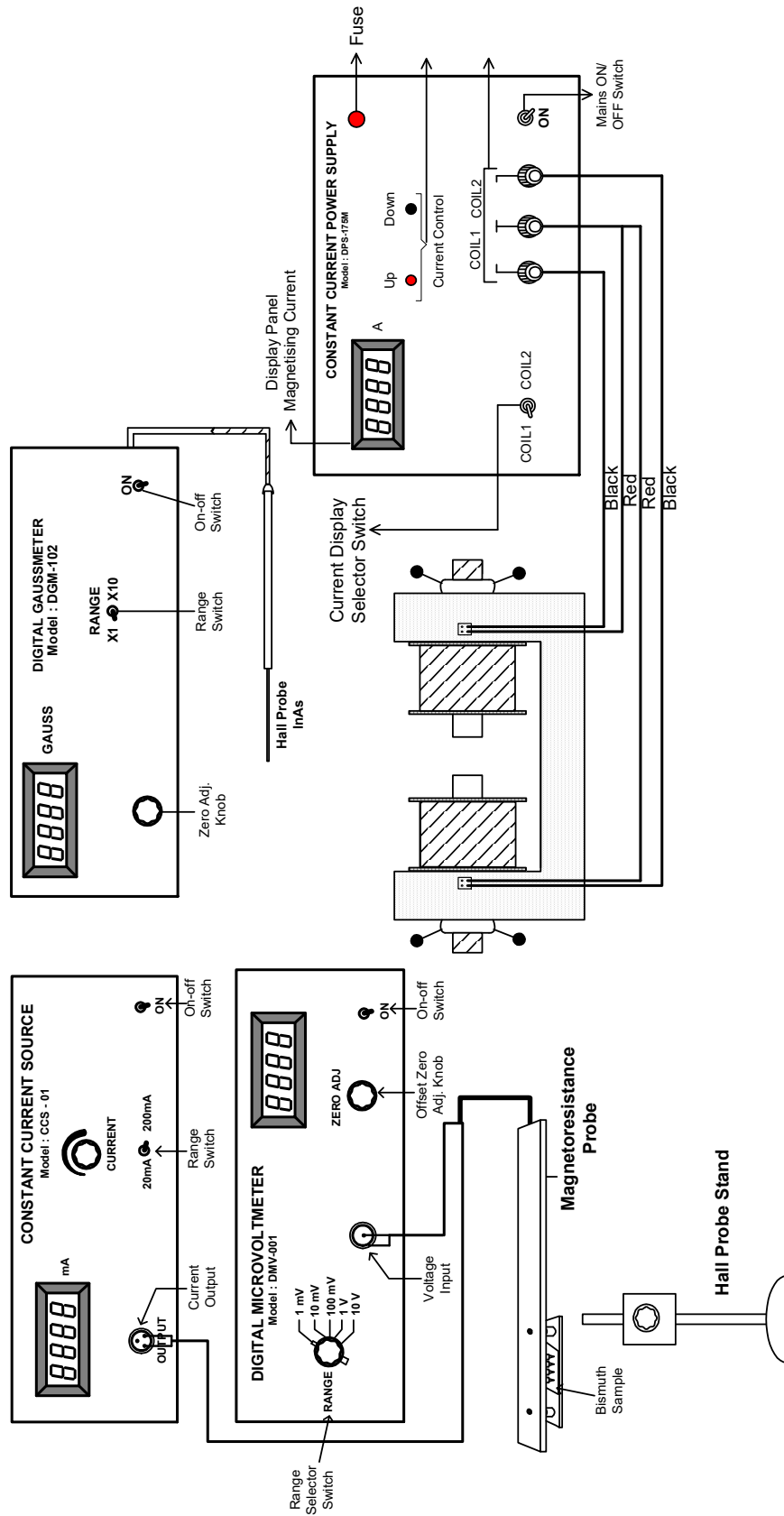

Fig.1: Panel Diagram of the magnetoresistance set up (for Hall effect magnetoresistance probe is replaced by Hall probe)

BRIEF DESCRIPTION OF THE APPARATUS

(1) Four Probe arrangement

It consists of 4 collinear, equally spaced (2mm) and individually spring loaded gold plated rounded probes mounted on a PCB strip. Two outer probes are for supplying the constant current to the sample and two inner probes for measuring the voltage developed across these probes. This eliminates the error due to contact resistance which is particularly serious in semiconductors. A platform is also provided for placing the sample and mounting the four probes on it.

(2) Samples

a) Magnetoresistance Bismuth dimensions: 10 x 10 x 1.2 mm.

Hall effect Bismuth dimensions:

CAUTION: The sample is quite brittle. Therefore, use only the minimum pressure required for proper electrical contacts.

b) Hall effect of Bismuth sample

Bismuth strip with four spring type pressure contacts is mounted on a sun mica decorated bakelite strip. Four leads are provided for connections with measuring devices.

SPECIFICATIONS

Contacts	:	Spring type (Solid Silver)
Hall Voltage	:	0.1 - 1 Volt/100 mA/KG
Thickness of Bismuth	:	0.4 - 0.5mm (provided to you)
Resistivity	:	$\cong 1.3 \cdot 10^{-4} \Omega \text{cm}$

The exact value of thickness and resistivity is provided. After calculating the Hall Coefficient from this experiment and using the given value of resistivity one can also get valuable information about **carrier density and carrier mobilities**

(3) Constant Current Source, Model: CCS-01

It is an IC regulated current generator to provide a constant current to the outer probes irrespective of the changing resistance of the sample due to change in temperatures. The basic scheme is to use the feedback principle to limit the load current of the supply to preset maximum value. Variations in the current are achieved by a potentiometer included for that purpose. The supply is a highly regulated and practically ripples free d.c. source. The constant current source is suitable for the resistivity measurement of thin films of metals/ alloys and semiconductors like germanium.

SPECIFICATIONS

Range	:	0 - 200.0 mV
Resolution	:	100 μV

Accuracy	: $\pm 0.1\%$ of reading ± 1 digit
Impedance	: 1 ohm
Special Features	: Auto Zero & polarity indicator
Special Features	: Auto Zero & polarity indicator
Overload Indicator	: Sign of 1 on the left & blanking of other digits.

Controls

- (1) **Range Switch** – The current meter can be switched between 20mA and 200mA range using this switch. Keep the range switch at the desired range and set the desired current using the current control knob. In case the meter shows over ranging (sign of 1 on the left and all other digits goes blank) range switch maybe shifted to higher range.
- (2) **Panel Meter** – Display the current in mA.
- (3) **Current Control** – This is to feed the desired current in the Sample.
- (4) **Current Output** – Connect suitable connector from Four probe arrangement in this connector. This will enable the unit to feed desired current in the sample
- (5) **ON-OFF switch** – To power the unit ON/ OFF

(4) D.C. Microvoltmeter, Model DMV-001

Digital Microvoltmeter, DMV-001 is a very versatile multipurpose instrument for the measurement of low dc voltage. It has 5 decade ranges from 1mV to 10V with 100% over-ranging. For better accuracy and convenience, readings are directly obtained on 3½ digit DPM.

This instrument uses a very well designed chopper stabilized IC amplifier. This amplifier offers exceptionally low offset voltage and input bias parameters, combined with excellent speed characteristics.

Filter circuit is provided to reduce the line pickups of 50 Hz. All internal power supplies are IC regulated.

SPECIFICATIONS

Range	: 1mV, 10mV, 100mV, 1V & 10V with 100% over ranging
Resolution	: $1\mu\text{V}$
Accuracy	: $\pm 0.2\%$
Stability	: Within ± 1 digit
Input Impedance	: $>1000\text{M}\Omega$ ($10\text{M}\Omega$ on 10V range)
Display	: 3½ digit, 7 segment LED with auto polarity and decimal indication

Controls

- (1) **Range Switch** – The voltmeter can be switched between 1mV, 10mV, 100mV, 1V & 10V range using this switch. Keep the range switch at lowest range for better

accuracy. In case the meter shows over ranging (sign of 1 on the left and all other digits goes blank) range switch maybe shifted to higher range.

- (2) **Panel Meter** – Display the Voltage in mV/ V (as per setting of Range Switch)
- (3) **Zero Adj. Knob** – This is to adjust Zero of Microvoltmeter before starting the experiment.
- (4) **Voltage Input** – Connect suitable connector from Four Probe Arrangement in this connector. This will enable the unit to measure the voltage output of the sample
- (5) **ON-OFF switch** – To power the unit ON/ OFF.

5. Electromagnet, EMU-75

Field intensity : 11,000 \pm 5% gauss in an air-gap of 10 mm. Air-gap is continuously variable up to 100 mm with two way knobbed wheel screw adjusting system.

Pole pieces : 75 mm diameter. Normally flat faced pole pieces are supplied with the magnet

Energising coils : Two. Each coil is wound on non-magnetic formers and has a resistance of 12 ohms approx.

Yoke material : Mild steel

Power requirement : 0 - 100 V @ 3.5 A if connected in series.
0 - 50 V @ 7.0 A if connected in parallel

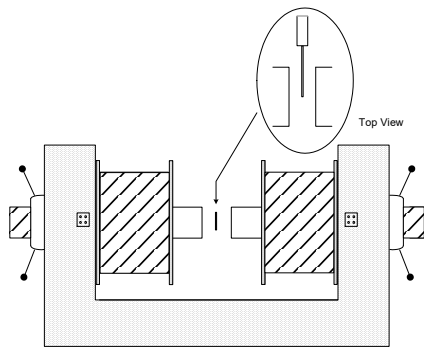

Fig. 2(a): Placing of Gaussmeter Hall probe in electromagnet

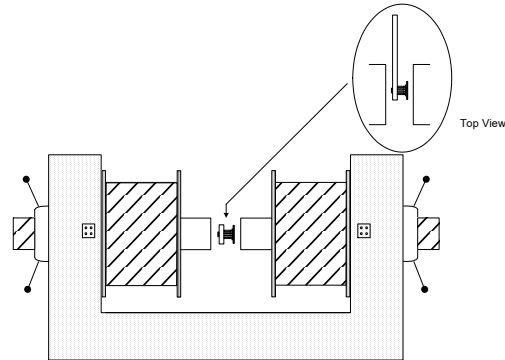

Fig. 2(b): Placing of Magneto-resistance sample probe in electromagnet



Fig. 3: Complete experimental set up

6. Constant Current Power Supply for electromagnet, DPS-175

The present constant current power supply was designed to be used with the electromagnet, Model EMU-75. The current requirement of 3.5 amp/coil, i.e. a total of 7 Amp was met by connecting six closely matched constant current sources in parallel. In this arrangement the first unit works as the 'master' with current adjustment control. All others are 'slave' units, generating exactly the same current as the master. All the six constant current sources are individually IC controlled and hence result in the highest quality of performance. The supply is protected against transients caused by the load inductance.

SPECIFICATIONS

Current	: Smoothly adjustable from 0 to 3.5 A. per coil, i.e. 7A
Regulation (line)	: $\pm 0.1\%$ for 10% mains variation.
Regulation (load)	: + 0.1% for load resistance variation from 0 to full load
Open circuit voltage	: 50 volt
Metering	: $3\frac{1}{2}$ digit, 7 segment panel meter.

7. Digital Gaussmeter, Model DGM-102

The Gaussmeter operates on the principle of Hall Effect in semiconductors. A semiconductor material carrying current develops an electro-motive force, when placed in a magnetic field, in a direction perpendicular to the direction of both electric current and magnetic field. The magnitude of this e.m.f. is proportional to the field intensity if the current is kept constant, this e.m.f. is called the Hall Voltage. This small Hall Voltage is amplified through a high stability amplifier so that a

millivoltmeter connected at the output of the amplifier can be calibrated directly in magnetic field unit (gauss).

SPECIFICATIONS

<i>Range</i>	:	0 - 2 K gauss & 0 - 20 K gauss
<i>Resolution</i>	:	1 gauss at 0 - 2 K gauss range
<i>Accuracy</i>	:	$\pm 0.5\%$
<i>Display</i>	:	: 3½ digit, 7 segment LED
<i>Detector</i>	:	Hall probe with an Imported Hall Element
<i>Power</i>	:	220V, 50 Hz
<i>Special</i>	:	Indicates the direction of the magnetic field.

7. Multipurpose Hall Probe Stand

PROCEDURE

(I) Magnetoresistance of Bi:

1. Set the pole piece distance of the Electromagnet to nearly 19mm (as closely as possible but to enough space for the magnetoresistance probe).
2. Inspect that electromagnet is producing magnetic field by sending current and measuring with Hall sensor.
3. Inspect that magnetoresistance preloaded with Bismuth responds to supply of current. Make sure that outer pair of probes to the CCS-01 terminals and the inner pair of the probes to DMV-001 terminals are connected.
4. Now place the magnetoresistance probe (as in Fig.3b) from one side and Hall sensor from other side vertically one upon other.
5. Fix the highest current possible with the constant current source. Record magnetic field versus voltage. Determine the resistance (R_m) in presence of magnetic field
6. Change the current to any other value suitable. Record magnetic field versus voltage. Determine the resistance (R_m) in presence of magnetic field
7. Measure voltages at zero magnetic field and calculate the resistance (R) of the sample.
8. Calculate $\Delta R (= R_m - R)$. Determine magnetoresistance by plotting $(\Delta R/R)$ Vs. H or $\log(\Delta R/R)$ Vs. $\log H$ for both currents.

(II) Hall effect of Bi:

1. Replace the magnetoresistance probe with Hall probe with preloaded sample.

2. Make sure that there is change in voltage with current at zero magnetic field.
3. Note down the offset voltage (which is due to IR drop), if any, by keeping Hall probe with sample away from the electromagnet
4. Fix a current with constant current source
5. Vary the magnetic field and record magnetic field versus Hall voltage and adjust the Hall voltage with the offset voltage measured. (offset due to IR drop can be also eliminated by reversing the magnetic field direction and taking the average Hall voltage readings of both the directions as described in the theory section)

OBSERVATIONS

(I) Data for magneto resistance Bi:

Tables (two tables for two different currents)

S.No	Mag. Field H (kG)	Voltage V_m (mV)	R_m (Ω)	$\Delta R/R$	Log (H)	Log ($\Delta R/R$)

(II) Hall effect of Bi

Tables (two tables for two different magnetic fields)

S.No	Mag. Field H (kG)	Hall Voltage V (mV)

Plot magnetic field versus Hall voltage for two magnetic fields and determine the Hall coefficient.

Example Graphs:

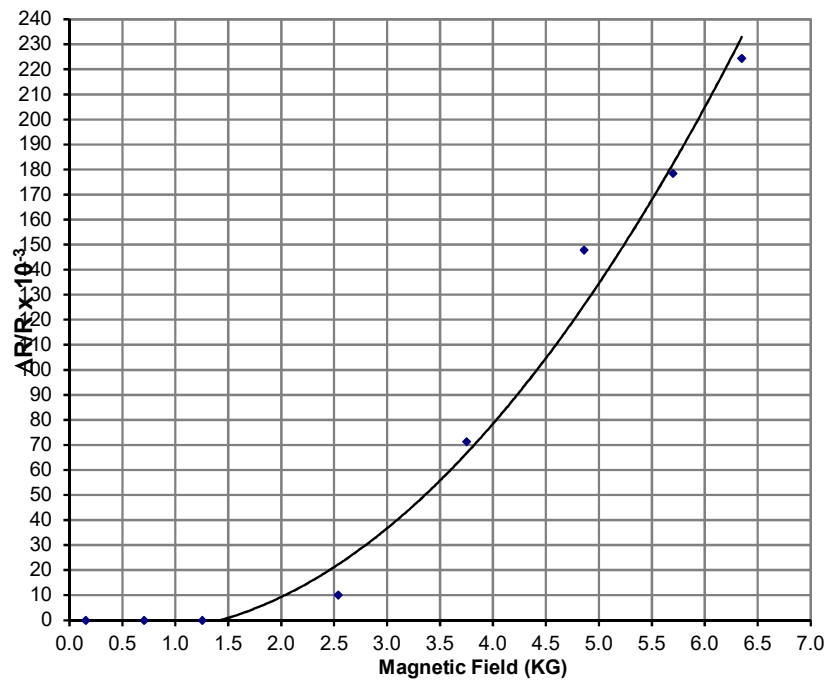

Reference: User manual from SES







GENERAL SAFETY SUMMARY

To use the Instrument correctly and safely, read and follow the precautions in Table 1 and follow all safety instructions or warnings given throughout this manual that relate to specific measurement functions. In addition, follow all generally accepted safety practices and procedures required when working with and around electricity.

SYMBOLS

Table 1 lists safety and electrical symbols that appear on the Instrument or in this manual.

Table 1. Safety and Electrical Symbols

Symbols	Description	Symbols	Description
	Risk of danger. Important information. See Manual.		Earth ground
	Hazardous voltage. Voltage >30Vdc or ac peak might be present.		Potentially hazardous voltage
	Static awareness. Static discharge can damage parts.		Do not dispose of this product as unsorted municipal waste. Contact SES or a qualified recycle for disposal.