

Analog to Digital conversion and Digital to Analog conversion with sample and hold (ADC-DAC-2)

Concept of Analog to Digital conversion is introduced in the first experiment (ADC-DAC-1) using the basic electronic components along with priority encoder and also limited to number of bits due to cumbersome circuit. In this experiment, electronic circuit of ADC-DAC-1 is replaced with dedicated Integrated circuit (IC). This experiment uses dedicated 8-bit ADC IC for analog to digital conversion and similarly 8-bit DAC IC for digital to analog conversion. Other important requirement for ADC circuit is sampling the signal and holding it till it is converted to digital format by ADC. Sampling and Holding is important for proper conversion of analog signals which we see every day in the lab. All multichannel analyzers also use ADC. Sampling rate is one important characteristic of Digital Oscilloscope.

Importance of sampling:

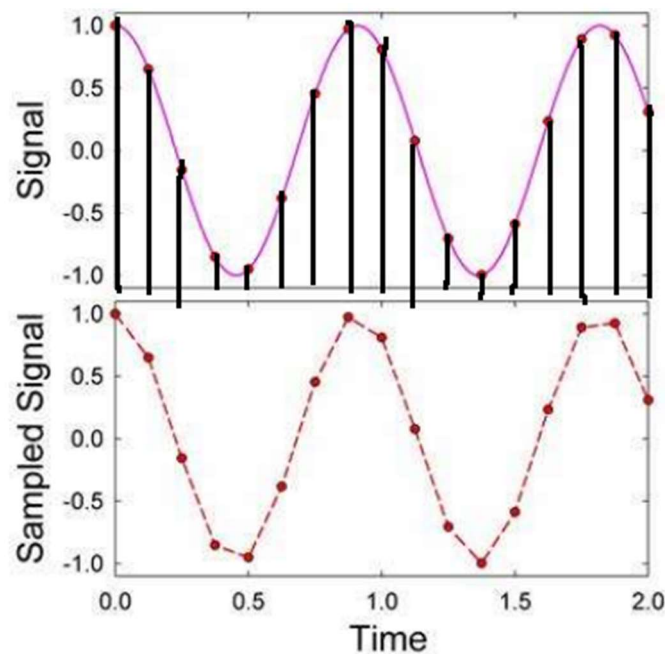

Fig.1. signal and sampled signal (original picture from <https://instrumentationlab.berkeley.edu/Lab10>)

The top part of the above picture is the signal and solid lines are the places on time axis where it was sampled. By connecting the sampled voltages at different times (dots), sampled signal is constructed which is the approximation of the signal. Approximation accuracy depends on the sampling rate and resolution.

Objectives of the experiment:

- 1) Hands-on observe the sample and hold output and learn the importance of sample and sampling frequency which is provided by the clock
- 2) Hands-on reproduce the input signal which is input to the ADC with complete ADC-DAC circuit at the output of the DAC.
- 3) Determine the minimum **ratio** of sampling frequency to sine wave input signal for reproducing chosen frequency of sine wave signal

Description of the experiment:

Complete circuit diagram for the ADC –DAC circuit with sample and hold is given in Fig.2. It consists of four parts

- a. Sample and Hold circuit
- b. Analog to digital conversion
- c. Digital to analog conversion
- d. Transimpedance amplifier.

Input sine wave signal (V_{in}) is digitized and then converted to analog format to reproduce the sine wave at the output (V_o). How well the signal reproduces depend on sample and hold, ADC resolution, DAC resolution etc.

Sample and Hold circuit: It is constructed with LF398 IC. Use of this circuit is to sample the input signal and hold until it is converted to digital format. Sample mode captures the signal at that instant of time and Hold mode holds the signals (charge stored in capacitor) captured.

Sample and Hold circuit requires a clock signal. In this experiment we use the external clock and for this we use a function generator.

Analog to Digital conversion circuit: It is constructed with ADC0804 IC, which is an 8-bit successive approximation ADC converter. It also has internal clock to give clock pulse to sample and hold circuit but we do not use in this experiment due to noise in the clock pulse signal.

Digital to Analog conversion circuit: It is constructed using DAC0808 IC, it is an 8 bit DAC chip with R-2R ladder. It comes in two different packages and we use DIP (dual in line package) for this experiment. Output of this IC is given by the equation

$$I_0 = K \left(\frac{A_1}{2} + \frac{A_2}{4} + \frac{A_3}{8} + \frac{A_4}{16} + \frac{A_5}{32} + \frac{6}{64} + \frac{A_7}{128} + \frac{A_8}{256} \right), \text{ where } K = V_{ref} / R. \text{ For this experiment } V_{ref} = 5 \text{ volt and } R = 4.7 \text{ K.}$$

Transimpedance amplifier: Transimpedance amplifier is a current to voltage converter. It is constructed using 741 IC.

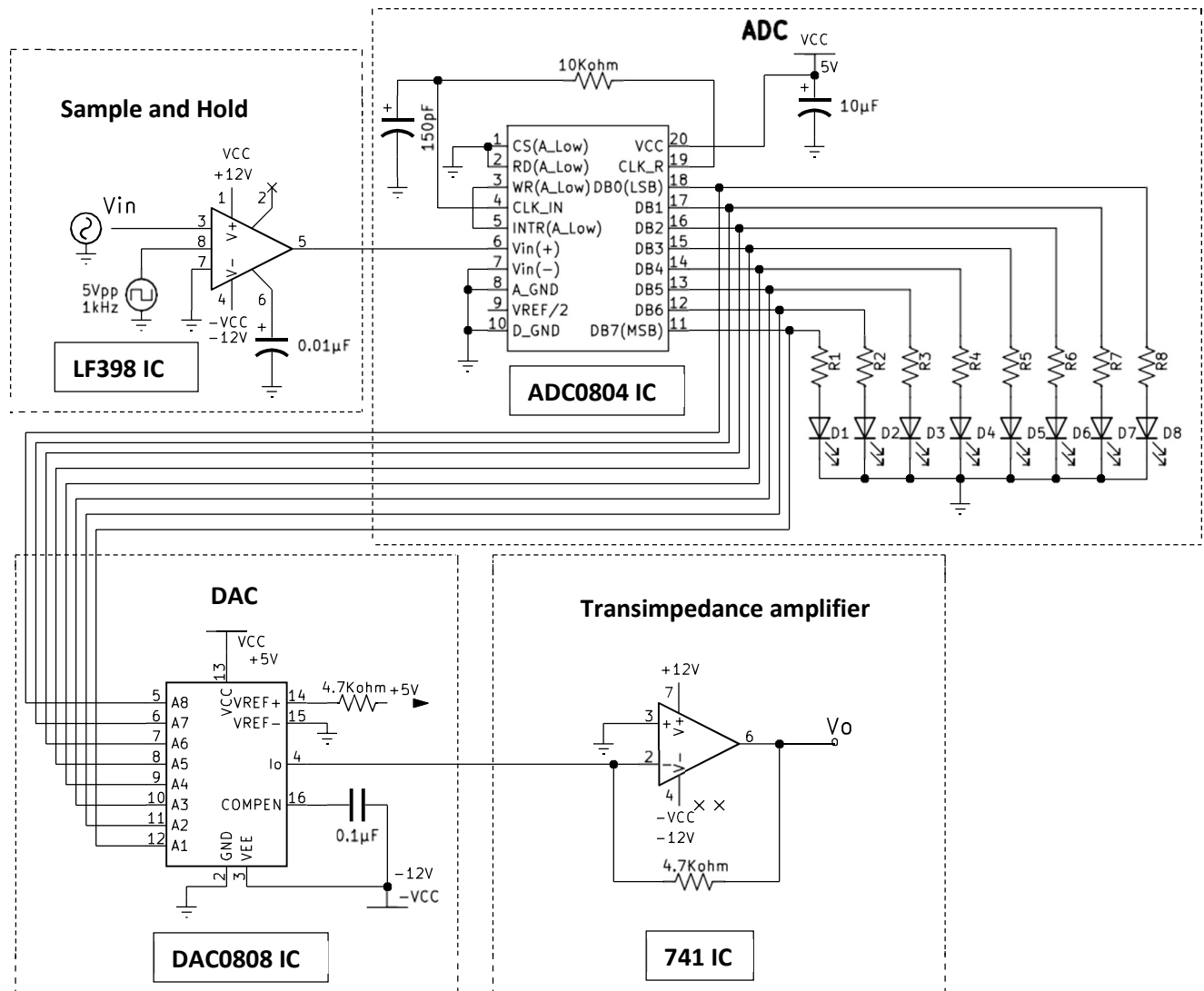

Fig.2: Circuit for ADC-DAC with sample and Hold

Components required: LF398 IC (for sample and hold), ADC0804 IC (for converting analog signal to digital signal), DAC0808 IC (converting digital signal to analog signal in the form of current output with dual in-line package IC), 741 (transimpedance amplifier to convert current to voltage output), resistors, capacitors, LEDS (8 number), R1-R6 use 330 ohm resistors, necessary cables.

Note. For sample and hold circuit use good quality capacitor such as mica, polystyrene or polypropylene dielectric. Do not use ceramic capacitor.

Instruments required: DC power supply, Function generators (2 no.) and Oscilloscope

Observations:

1. In step1, construct the sample and hold circuit, choose sampling frequency as 5 Volt V_{p-p} 1 kHz square wave from first function generator and signal frequency as 100 Hz sine wave of amplitude. Observe that sample and hold is working. Take a picture of oscilloscope display.
2. In step2, construct the ADC circuit. Initially give a fixed voltage from the power supply using voltage range (0 to 5 Volt) and observe the binary output using LEDs and verify that it is working by noting down the binary output corresponds to input. Tabulate the input versus digital output.
3. In step3, Connect the sample and hold circuit output to ADC circuit and observe the output of first two parts is continuously changing by observing the LED output as per the sine wave input. No need to note down any observations for this step.
4. In step4, construct DAC circuit and transimpedance amplifier circuit together. Provide digital input to DAC circuit (either giving 0 or 5 Volt to pin numbers 5 to 12 of DAC0808 IC) and check the voltage output of amplifier to verify the working of the last two parts of the circuit.
5. In step5, connect individual circuits to make complete circuit as in Fig.2, choose sine wave of 10 Hz with approximately 1 Volt V_{p-p} as input frequency and clock as 1 KHz square wave 5 volt V_{p-p} . Observe that input is reproduced as output. Record the same by taking pictures.
6. In step6, observe the effect of increasing the input signal frequency and record. Interpret the results.

Questions: What is acquisition time for sample and hold circuit? How it varies? What is the droop rate of sample and hold circuit? Which property of the capacitor is important for lower droop rate?

References:

- 1) Sample processing in oscilloscopes: <https://www.tek.com/en/blog/sample-processing-digital-oscilloscope>
- 2) Sample and hold characteristics. <https://www.electronicshub.org/sample-and-hold-circuit/>
- 3) LF398 data sheet: <https://www.ti.com/lit/ds/symlink/lf398-n.pdf>
- 4) ADC0804 data sheet: <https://www.ti.com/lit/ds/symlink/adc0804-n.pdf>
- 5) DAC0808 data sheet: https://www.ti.com/lit/ds/symlink/dac0808.pdf?ts=1672118884258&ref_url=https%253A%252F%252Fwww.google.com%252F
- 6) <https://instrumentationlab.berkeley.edu/Lab10>
- 7) https://www.medicine.mcgill.ca/physio/vlab/biomed_signals/atodvlab.htm